

## SPECIFICATIONS

Nominal Input Level		- 8 dBv
Input Impedance		10 Mohms (Ch A), 1 Mohms (Ch B)
Output Impedance		10 kohms
Frequency Response	+0 / -3 dB	20 – 20 kHz
Tone Controls	Bass	+/- 15 dB @ 100 Hz
	Treble	+/- 15 dB @ 10 kHz shelving
	Bright	+ 12 dB @ 10 kHz, 15dB gain
	Midrange	+/- 12 dB
	Frequency Range	50 – 2.000 Hz
	Q	0.80
	Edge	+/- 12 dB @ 7 kHz
Boost Control	Gain	0 – 30 dB
Drive Control	Gain	0 – 35 dB
	Gain Type	Class A Tube Emulator
Balanced Output	Low End Compensation	< 250 Hz
	Impedance	500 ohms balanced
	Nominal Level	-10 dBv
	Frequency Response	+0/-3 dB 20 Hz – 30 kHz
	XLR Connections	1-GND, 2-Hot, 3-Cold
Phones	Options	GND Lift, Speaker Simulator
	Impedance	3 – 200 ohms recommended
Power Requirements		9 V DC Regulated, 10 mA
		15 mA with Phones
Powering Modes		DC Power Supply, Battery,
		48V Phantom power,
		EBS Phantom Power System
Dimensions		6.0" (153 mm) Width,
		4.3" (110 mm) Height,
		2.3" (58 mm) Depth
Weight		875 g (1.95 lb.)

*Specifications are subject to change without notice!*

## EBS MicroBassII

MADE IN SWEDEN BY EBS SWEDEN AB

✉ FRAMNÄSBÄCKEN 12, SE-171 66 SOLNA, SWEDEN

☎ +46-8-735 00 10, FAX: +46-8-735 00 15

E-MAIL: [ebs.sweden@bass.se](mailto:ebs.sweden@bass.se)

WEB: <http://www.ebs.bass.se>



November 2003

# USERS MANUAL

## BLACK LABEL SERIES

### EBS MICROBASSII



EBS PROFESSIONAL BASS EQUIPMENT

# MicroBass III

CONTENTS:	PAGE:
<b>GETTING STARTED:</b>	
DIRECT INJECTION BOX	3
USING ONE INSTRUMENT	4
USING TWO INSTRUMENTS	5
REHEARSAL PREAMP	6
GOOD TO KNOW	7
<b>THE CONTROLS AND FUNCTIONS:</b>	
CHANNEL A:	
INPUT • BOOST	8
BASS • TREBLE	
BRIGHT • ENHANCED FILTER	9
CHANNEL B:	
MIDDLE • EDGE	10
DRIVE • MODE SWITCH	11
COMMON FEATURES:	
TUBE SIM • CONTROL SWITCHES	12
EFFECTS LOOP	
BALANCED OUTPUT	13
VOLUME • INDICATORS	
POWERING MODES	14
BATTERY REPLACEMENT	
<b>TECHNICAL REFERENCE:</b>	
BLOCK DIAGRAM	15
TECHNICAL SPECIFICATIONS	16

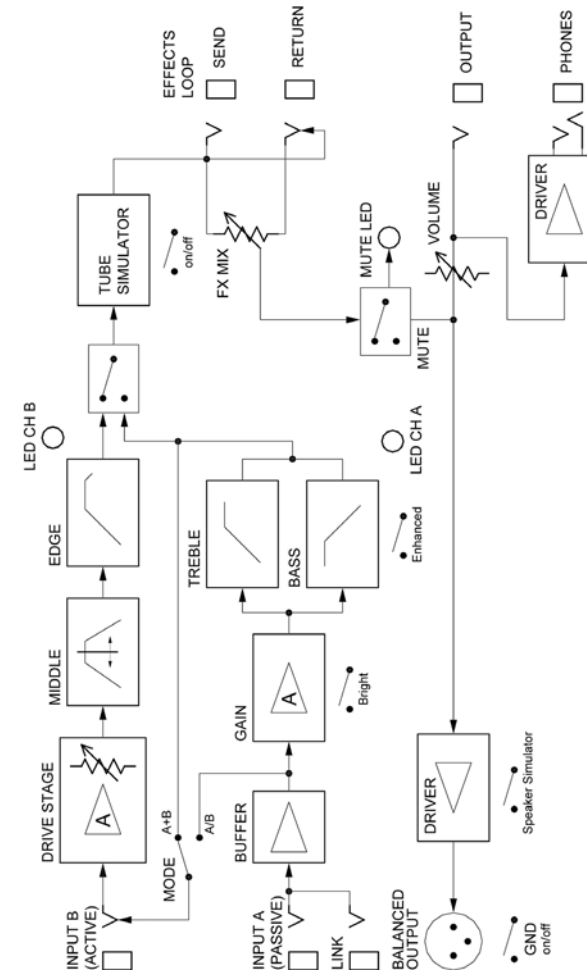

1. **DC Adapter:** EBS recommends the use of the EBS AD-9 DC power supply, which supplies a well-stabilized power to the EBS MicroBassII.
2. **EBS Phantom Power™:** The Phantom Power option allows you to power the MicroBassII from another EBS product such as the GormET/Drome bass combos or EBS-active cabinets and so on. When using the phantom power, you need to connect a stereo ¼" cable between the OUTPUT from the EBS-MicroBassII and the input jack of the amplifier, or if option is available on the amp, to the effect return jack. Please refer to the amps user manual on how to engage this on the amp.
3. **48V Phantom:** This is the standard microphone phantom power option found on mixing consoles and is fed through the balanced XLR output. Refer to the operating instructions of the mixing console being used for further reference on how to activate the 48V phantom power.
4. **9V Battery:** Use a long-life alkaline battery for best performance. Note that the battery doesn't need to be removed when using another powering mode. The battery will not be surged or charged.

#### BATTERY REPLACEMENT:

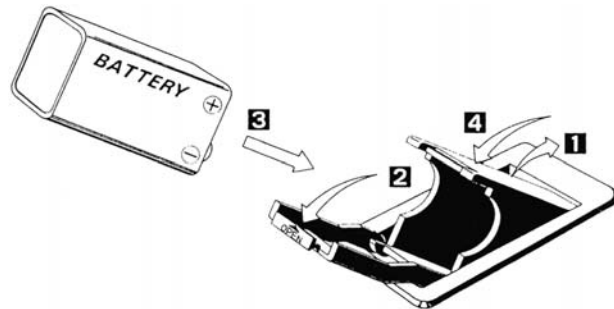

14

*Thank you for choosing the EBS MicroBassII professional outboard preamp. This manual will describe how to get the most out the MicroBassII preamp. In this first section we will describe the basic modes of operation and give you a couple of hints. The second section describes more in detail the different function and options available for your use.*

**GOOD LUCK!**

#### THE DIRECT INJECTION BOX MODE:

- 1) Connect your instrument to input A.
- 2) Connect to the amplifier from output LINK.
- 3) Set the A/B switch so that Channel A is active.
- 4) Set the BASS and TREBLE controls to 12 o'clock and the BOOST to minimum position.
- 5) Make sure no option switches are selected into inner position.
- 6) Connect to mixer from the Balanced XLR Output.

Now you have selected the active DI option with perfectly flat frequency response. Depending upon your instrument you may change the input sensitivity with the Boost control up to the choice of your own.

3

## USING ONE INSTRUMENT MODE:

- 1) Connect your instrument to input A.
- 2) Connect the Output to power amplifier or amplifier head.
- 3) Set the A/B switch so that Channel A is active.
- 4) Set the BASS and TREBLE controls to 12 o'clock and the BOOST to minimum position.
- 5) Set the DRIVE control to minimum position and the MIDDLE and EDGE to 12 o'clock.
- 6) Make sure all switches are in the outer position.
- 7) Connect to mixer from the Balanced XLR Output if required.

You can now dial in two different sound on the A and B channels respectively. By engaging the A+B mode switch you may now dial in your basic sound on channel A, and when selecting B you will add the B to the A channel. This is useful for overdriven sounds and lead playing. Both LED's will now light.

**BALANCED OUTPUT** - Is a high quality balanced output. The balanced output functions as an interface for connecting to PA mixing consoles or to studio or broadcast recording units.

Lifting ground is a great aid in many occasions. When required, set the Gnd Lift switch to its' inner position to disconnect the ground from the output.

Note: **You cannot use the 48V phantom powering option when the ground is lifted!**

The EBS MicroBassII features a speaker simulator for the balanced output. This feature is tuned together with a speaker cabinet in order to send the same sound image from the preamp as heard on stage. To activate this function press the Spkr Sim switch.

---

**VOLUME** - The VOLUME knob controls the output volume for the OUTPUT and PHONES outputs. The balanced output (XLR) is not affected by the setting of this knob.

---

**HEADPHONES** - The headphones output enables you to use the MicroBassII as a rehearsal amp, or to play without a poweramp/speaker cabinet configuration. When using the headphones you should not use the 48V phantom power option due to the high power consumption.

---

## THE INDICATORS:

- **A**: Channel A active.
- **B**: Channel B active.
- **MUTE**: Preamp is muted.
- **48V**: Microphone phantom power is powering the preamp.
- **Batt.**: Low battery. Replace the battery immediately.

**TUBE SIM.** – This switch engages the tube simulation circuitry for the MicroBassII. In difference from the Drive circuitry this simulator is static and works only on fairly high levels, giving a soft clip limiting effect.

**EFFECTS LOOP** – EBS MicroBassII is provided with an effect loop for the use of external units such as box or rack effects.

**FX MIX** - Controls the amount of effect, all from 0% up to 100%. When set to 100%, the effects loop is purely serial, and when the effects blend is 50%, the effects loop works in parallel mode.

The effect loop is put before the balanced output, so the effect signal will be present at the balanced output.

---

## THE CONTROL SWITCHES:

There are two footswitches for rapidly changing the state of the EBS MicroBassII:

**A/B:** Selects active channel A or B. If the Mode switch on channel B is set to A+B, this switch selects channel A active or channel A **AND** B. When using both inputs and the A+B mode is selected, you have the A and B mix mode selected, so then this switch has no effect and no channel LED will light.

**MUTE:** Mutes the Output, Headphones output and Balanced Output. This is useful when changing instruments or when tuning. The Link output from channel A is not muted with this switch.

## USING TWO INSTRUMENTS MODE:

- 1) Connect the first instrument to input A and the second to input B. Normally you would connect the instrument with lowest output to channel A.
- 2) Connect the Output to power amplifier or amplifier head.
- 3) Set the A/B switch so that Channel A is active.
- 4) Set the BASS and TREBLE controls to 12 o'clock and the BOOST to minimum position.
- 5) Set the DRIVE control to minimum position and the MIDDLE and EDGE to 12 o'clock.
- 6) Make sure all switches are in the outer position.
- 7) Connect to mixer from the Balanced XLR Output if required.

You may now switch the instruments with the A/B foot switch. Adjust the gain and EQ on the individual channels for personal taste.

By engaging the A+B mode switch you will enter the mix mode, and both channels will be mixed equally rather than selected individually. This is useful for teaching purposes, but is also a very good feature if you wish to mix two different pickup systems, for example on an upright bass. Here is where a piezo pickup would be connected to channel A, and the standard pickup to channel B. In this mode no channel LED will light.

**REHEARSAL PREAMP MODE:**

- 1) Connect your instrument to input A.
- 2) Connect headphones to the headphones jack.
- 3) Set the A/B switch so that Channel A is active.
- 4) Set the BASS and TREBLE controls to 12 o'clock and the BOOST to minimum position.
- 5) Set the DRIVE control to minimum position and the MIDDLE and EDGE to 12 o'clock.
- 6) Make sure all switches are in the outer position.
- 7) Set the Volume to a moderate setting.

You have now a basic sound you may wish to adjust with a different gain and EQ settings.

You may now connect a CD player or another external source to the Effects Return jack. In this rehearsal mode, the FX MIX control will act as a balance between the background as connected to the return jack and your instrument. Very useful for practicing and while rehearsing.

**DRIVE** – The DRIVE knob controls the amount of gain in the tube emulation stage, and provides extra gain all the way up to 30 dB. When pushing this control to distortion, a tube like limitation is achieved

The lower midrange and bass frequencies are bypassed in the Drive stage, producing a warmer overdrive without saturation, allowing the player to add more low bass than with conventional preamps. The bass is compensated over the tube emulation stage, which gives the same bass response up to mid distorted sounds.

The additional filters MIDDLE and EDGE are located post the DRIVE control, which means that you are able to fine tune your overdriven tone further.

---

**A+B MODE SWITCH** – This switch controls how the B channel should work together with channel A.

In the outer position the channels operate separately, either by using one instrument connected to channel A, or two ones connected to A and B respectively.

In the inner position you have the option of putting channel B in series with channel A, so with the A/B switch you select either channel, A or channel A and B. The two channel LED's indicate the status accordingly. If you however have two instruments connected you will mix together the two channels equally. Since the A/B doesn't have any function, no channel LED will light. This last mode is very useful if you wish to mix two different pickup systems on one instrument.

**MIDDLE FILTER** – This filter has an extended frequency range from 50Hz to 2kHz and facilitates total control over the midrange, with a wide bandwidth giving a natural and non-peaking result.

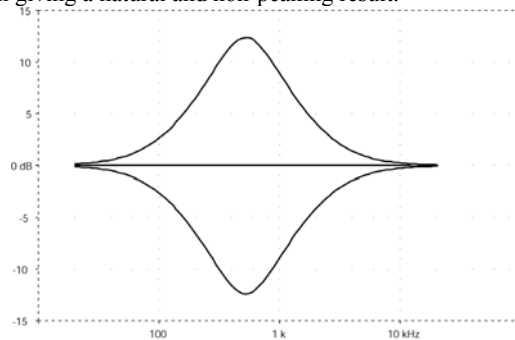

**EDGE FILTER** – The EDGE filter is a 'bell' type filter peaking at around 7kHz controlling the higher mids and treble registers, giving presence and “edge”.

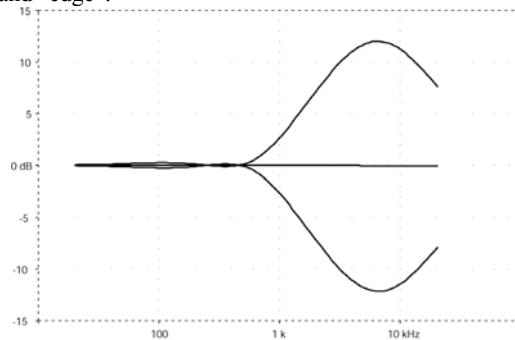

Both MIDDLE and EDGE filters are located after the DRIVE controls, which make them perfect for fine-tuning the overdriven sound.

### SOME HINTS:

- Once you have connected either input A or B, the battery is engaged.
- Avoid using the headphones while using 48V phantom power. The power drain may affect your signal.
- You do not need to remove the battery if you are powering the MicroBassII in another powering mode.
- If you are only using the OUTPUT, you may power up and down the MicroBassII without audible pops if the Volume knob is set to minimum.
- For normal operation, try to keep the Volume as high as possible.
- For best results, always gain up the MicroBassII from the Boost and the Drive controls in minimum position.
- The Gnd Lift option cannot be used together with 48V phantom power. Either phantom or ground lift.
- Trim the gains between the A and B channel in standard “A or B mode” with the Drive knob set to minimum. Then trim the gain with the Boost in channel A .

## INPUT • BOOST

**INPUT A** - A very low noise input suited for all types of instrument. The very high impedance (10Mohms) makes this input suitable for sensitive piezo pickup systems. This is the default input.

**BOOST** - Control to adjust the instruments' signal strength to the right operating level in the EBS MicroBassII. This control goes from unity gain all the way up to 30dB with low noise. For best results, always try to gain from minimum position.

## THE FILTERS:

The MicroBassII is equipped with very efficient filter controls to help you shape the sound further.

### BASS and TREBLE FILTERS:

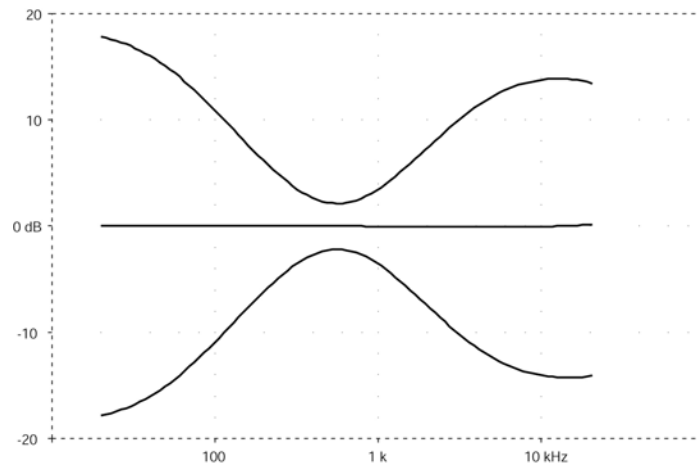

8

## BRIGHT • ENHANCED FILTER

**BRIGHT** – The bright is an advanced high pass filter capable of producing bright high treble timbre, without adding practically any noise. It gives 12dB boost at 10kHz and may give brightness to old passive pickups.

**ENHANCED FILTER MODE** – The enhanced mode switch allows the Treble control to have effect on the midrange in this filter. When boosting the treble, the middles will be cut and vice versa. This function is fully separated from channel B's MIDDLE filter.

### Normal filter mode TREBLE:

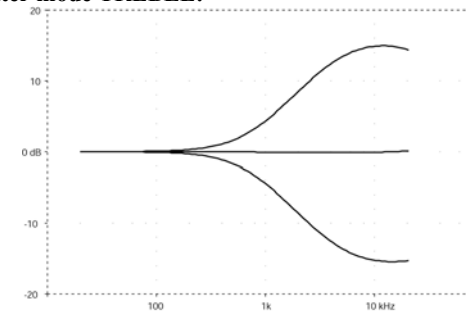

### Enhanced filter mode TREBLE:

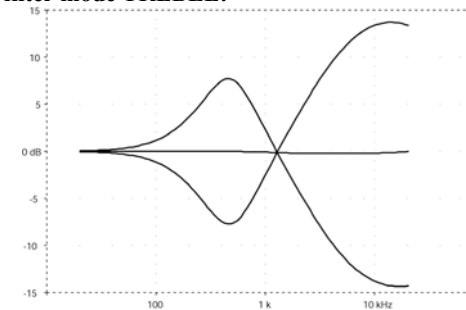

9